



**PRODUCT MANUAL
AFA-AWG20L**

CONTENT

1. Introduction
 - Copyright
 - Limitation of Liability
 - Fields of application
2. Security notes
3. Precautions
4. Description of features
5. Test features
6. Components
7. Operation
8. Initial commissioning
9. Dispensing of water
10. Changing filters
 - Reset flashing filter warning
 - Replace Air filter
 - Replace water filters
 - Replace LED-UV lamp of the bottom tank
 - Replace LED-UV lamp of the top tank
11. Flushing, cleaning and disinfection
 - Flushing the device
 - Cleaning the bottom tank
 - Device disinfection
12. Connection of additional water sources
13. Complete drainage
14. Trouble shooting
15. Solutions of other problems
16. Technical specifications

- ✧ The AFA-AWG20L must be in vertical position 24 hours before using.
- ✧ Keep the machine running till the water level on the screen to reach 3/4, then drain all water from the 2 water outlets (white plastic nut cap) which located at the back middle part of the machine when you use the machine at the first time.
- ✧ Do not forget to change filters in time.

1. INTRODUCTION

Thanks for purchasing AFA-AWG20L (atmospheric water generator).

1. This appliance is intended to be used in household and similar applications such as: (IEC60335-2-15)
 - staff kitchen areas in shops, offices and other working environments;
 - farm houses;
 - by clients in hotels, motels and other residential type environments; -bed and breakfast type environments.
2. Appliances can be used by persons with reduced physical, sensory or mental capabilities or lack of experience and knowledge if they have been given supervision or instruction concerning use of the appliance in a safe way and understand the hazards involved.
3. Do not store explosive substances such as aerosocans with a flammable propellant in this appliance.
4. Children shall not play with the appliance.
5. Cleaning and maintenance shall not be made by children without supervision
6. No installation required for AFA-AWG20L, just plug into the power source and follow the instructions in this manual.
7. After switching on AFA-AWG20L, the machine will start to produce, purify and store the cold and hot water up to 20 liters per day, based on the ambient temperature 30°C and related humidity 80%. 8. AFA-AWG20L is easy to operate, environmentally friendly, clean and healthy.

Copyright

This documentation is protected by copyright. Any reproduction, reprint, even partially as well as the reproduction of images, even in an altered state, is only allowed with the written consent of your supplier.

Limitation of Liability

All technical information, data, wiring and operating instructions contained in this product manual correspond to the latest state of the art at the time of printing and have been made to the best of our knowledge and experience. No claims can be derived from the data, illustrations, and descriptions in this product manual. Supplier is not liable for damages resulting from non-observance of the product manual, improper use, improper repairs, unauthorized changes, or the use of unauthorized spare parts.

Fields of Application

AFA-AWG20L is designed exclusively for the water production from air above 15°C and 30% humidity environment condition.

Suggest AFA-AWG20L to be used indoors environment. If AFA-AWG20L is used in other environment where could lead to injuries and/or machine damage, Supplier is not liable for any damage caused by improper use.

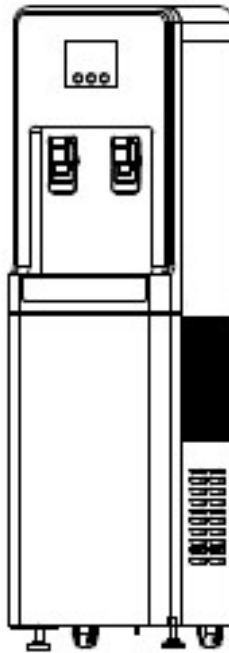

Product Exterior Diagram

2. SAFETY NOTES

- 2.1. The electrical outlet shall be equipped with a reliable and correct grounding
- 2.2. Do not disconnect the grounding plug from the power cord
- 2.3. Do not use an extension cord or power adapter
- 2.4. Do not use damaged power cords or plugs
- 2.5. Always turn off the AFA-AWG20L by unplugging the power cord before servicing
- 2.6. Do not plug in or unplug the power cord with wet hands
- 2.7. Do not share the power outlet with other machines
- 2.8. Suggest to use replacements and consumables supplied by supplier
- 2.9. Improper repairing will not be protected by warranty policy
- 2.10. Unplug the power cord and empty the water from all tanks before moving AFA-AWG20L
- 2.11. Do not tilt the AFA-AWG20L more than 20° while moving it. If the device is tilted by more than 20°, it must remain in an upright position for at least 24 hours before re-connecting to the power supply
- 2.12. Avoid prolonged eye contact with the ultraviolet LED-UV lamp
- 2.13. Warm water is heated to 85°C, please keep your body and skin away from the hot water to avoid injuries

2.14. CAUTION – LED-UV light source - disconnect the power supply from the LED-UV before opening the cover

2.15. CAUTION - TO AVOID RISK OF FIRE OR ELECTRIC SHOCK, USE THE MACHINE ONLY INDOOR. SEE FURTHER INFO IN PRODUCT MANUAL

2.16. Install AFA-AWG20L away from toxic gases or aggressive liquids

3. PRECAUTIONS

3.1. It is forbidden to install and use AFA-AWG20L in areas where there is a risk of explosion.

3.2. It is forbidden to install and use AFA-AWG20L in areas where the air contains oil, sulfur, chlorine or salt.

3.3. This AFA-AWG20L is not intended for outdoor use away from indoor areas

3.4. It is forbidden to wash AFA-AWG20L with a jet of water

3.5. Do not place any objects on the AFA-AWG20L

3.6. It is forbidden to cover the intake and exhaust ports

3.7. It is forbidden to insert any objects into AFA-AWG20L

3.8. It is forbidden to cover or move the switched-on AFA-AWG20L

3.9. Operate AFA-AWG20L in an upright vertical position

3.10. All electrical cables must be secured against damage

3.11. Check that the extension cord meets the power, length, and destination requirements.

3.12. The switching voltage must not fall below 10% of the standard supply to avoid increased noise or overheating. If this happens, disconnect AFA-AWG20L from the power supply immediately until the voltage returns to normal

3.13. Young children must not use AFA-AWG20L without adult supervision 3.14. Position AFA-AWG20L in an area where it will not hinder or injure people by hitting the machine or spill water in the lower tank and cause an E7 error (see 14. Trouble shooting)

3.15. The AFA-AWG20L can only be operated in a vertical position, and the machine must be completely empty before each operation (see 13. Complete drainage)

3.16. Please follow product manual for detailed instructions before using AFA-AWG20L

3.17. It is forbidden to use AFA-AWG20L for purposes other than those specified in this product manual

3.18. In case of non-observance of these instructions, supplier is not liable for any damages and the warranty cannot be applied

Important electrical connection information

AFA-AWG20L must be connected to the power source in accordance with current standards for power supplies equipped with static circuit breakers. If AFA-AWG20L is

used in damp areas, the machine must be equipped with a static electricity circuit breaker which shall be provided by user to meet the conditions of such areas.

4. DESCRIPTION OF FEATURES

- 4.1 AFA-AWG20L uses an eight-stage filtration process to produce clean drinking water from the air. AFA-AWG20L extracts air through the ① Air filter which can prevent micro particles and dust entering into machine.
- 4.2 The cleaned air and water vapor go inside and contact with the evaporator where the water vapor freeze due to compressor refrigerant in coils.
- 4.3 Subsequently, the reverse function of the compressor heats up and the ice condenses into water, which drips into the water bowl of stainless steel, flows into the lower stainless steel tank, equipped with a ⑦LED UV lamp to remove bacteria and microorganisms.
- 4.4 Hi-tech pump pushes the water through water filters including ② Softening filter (SFT) to soften water by removing calcium ion, magnesium ion etc from water. Then go through ③ sediment filter (PPF) eliminating dirt and particles with a diameter of over 5 microns, further goes through ④ Ultrafiltration membrane filter (UF), eliminating micro-particles, plastics and particles of diameter less than 0.01 micron, ⑤ through pre-carbon filter (GAC) with coconut shells, which absorbs dangerous organic substances, such as chlorine, pesticides and some volatile organic compounds, and then through ⑥Electropositive Membrane filter (ELE), principally use adsorption (electro-adhesion) as the filtering mechanism with absolute rating of 0.2micron to filter contaminants such as virus, bacteria, colloid, particulates, trace pharmaceuticals in the water. Then the water is pumped into an upper stainless steel tank equipped with an additional ⑧ LED UV lamp to ensure that no other bacteria or microorganisms remain in the water.
- Two stainless steel tanks are located under the upper tank. One of them heats the purified drinking water to 85°C and the other cools the water to 6°C.

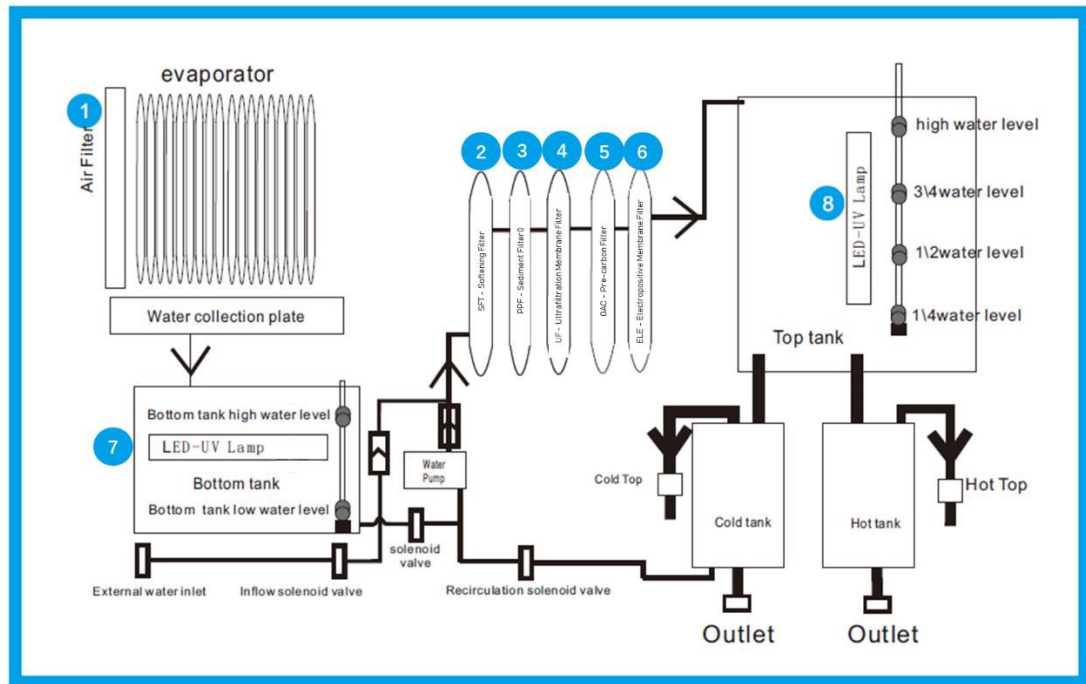

Working principle diagram of AFA-AWG20L

Note:

AFA-AWG20L has 1 option of connecting to an additional water source to ensure that it can provide a constant supply of clean drinking water in all conditions even in periods of low humidity, which is not suitable for a normal operation. Water from an external source can be filtered through the water filtration system in AFA-AWG20L, especially when the external water source is not such clean as purified water, i.e. water supply from water factory, other external separate water tanks, etc. AFA-AWG20L will automatically switch to use an additional water source if water in internal water tank is below the level that required for dosing or when the relative humidity is lower than the operating humidity.

5. TEST FEATURES

It is important to note that the actual performance of AFA-AWG20L is based on physical laws, which depends on the relative humidity and ambient temperature. Relative humidity “RH” is ubiquitous and penetrates through all porous materials. In general, the higher relative humidity and ambient temperature, the higher amount of water will be produced by AFA-AWG20L. Water production is determined according to the table below.

Temperature/ Humidity	Tab. 1. Production of water per 24hrs [litres]						
	30%	40%	50%	60%	70%	80%	90%
15°C	-	2.56	3.50	4.50	6.40	7.00	9.10
20°C	-	4.16	5.70	6.40	7.90	9.01	12.43
25°C	3.85	5.27	7.20	9.10	12.80	15.30	18.82
30°C	4.92	6.74	9.20	12.60	17.70	20.00	25.20

The estimated 24 hours water production of AFA-AWG20L depends on the relative humidity and ambient temperature, generally provided by Mollier diagram (also IX HS or psychometric chart used by axis). AFA-AWG20L can produce up to 20 liters of pure water from the air based on 30°C and RH 80%.

The operating environment condition range for AFA-AWG20L is RH from 30% to 99% and temperature from 15°C to 45°C.

By considering optimal, cost-effective and safe use, AFA-AWG20L must comply with the following conditions:

- 1) AFA-AWG20L must be positioned at least 30 cm from any walls or other structures from all sides, such as by placing in the middle of the long wall for optimum air circulation in the space.
- 2) It is still necessary to supply fresh moist air, choose the location wisely, such as lobby, corridors, halls, auditoriums, covered terraces and roofs, kitchen, the dining room and forced air change, or high concentrations of relative humidity, such as gyms, winter gardens etc. Otherwise it may cause dry air in the room and improper machine operation.
- 3) AFA-AWG20L must not be installed next to radiators or heaters.

By the way, the best time of water production for some places is at night (due to higher relative humidity in the night).

6. COMPONENTS

6.1 Microcomputer - controls water production, collection, filtration, storage, heating, cooling and distribution of water that this device generates from the air

6.2. Electronic sensor - controls LED UV lamp, temperature, water levels, energy efficiency, maintenance, security and other features
6.3. Sensors for saving energy - control the process of making water from air with maximal efficiency

6.4. Hot water lock- prevents accidental dispensing of hot water from AFA-AWG20L

6.5. Venturi blower - designed to provide maximum efficiency and reduced noise levels

6.6. Water leak detector - in case leaking, AFA-AWG20L will stop working and automatically displays error E7 on control panel (see 14. Trouble shooting)

6.7. Connection set - a set of water hoses can be connected directly to the tap or supply pipe, which allows AFA-AWG20L to function as a water purifier using a device filtering and disinfection system. Additional installation instructions (see 12. Connection of additional water sources)

6.8. Power switch - control the total power supply of AFA-AWG20L. AFA-AWG20L start to work when it is turned on and stop working when it is turned off.

6.9. Hot water switch - hot water function, make sure that the hot water switch (red) is switched to "ON" position UP. Water heating switch must be turned on for at least 30 minutes, then the water can be heated to 85°C.

6.10. Cold water switch - cold water function, make sure that the cold water switch (black) is switched to "ON" position UP. Cold water switch must be turned on for at least 30 minutes, then the water can be cooled to 6°C.

6.11. 8 steps filtering process: the fan system extracts air and pushes it through the air filter. Water vapor in the air contact with the coils of stainless steel and condensation occurs, produces water. Then the water will pass through the next 7 steps filtration, which can remove chlorine fluoride, lead or other harmful ingredients, then produces up to 20 liters clean drinking water per day.

- ① Air filter - it prevents dust and micro particles penetration of the device and cleans air
- ② Softening filter (SFT) - soften water by removing calcium ion, magnesium ion etc from water.
- ③ Sediment filter (PPF) - eliminating dirt and particles having a diameter of over 5 microns
- ④ Ultrafiltration Membrane filter (UF) – ultrafine filter eliminates particles smaller than 0.01 microns.
- ⑤ Pre-carbon filter (GAC) – charcoal and coconut shells absorbing hazardous organic compounds, such as chlorine, pesticides and some volatile organic compounds.
- ⑥ Electropositive Membrane filter (ELE) - principally use adsorption (electro-adhesion) as the filtering mechanism with absolute rating of 0.2micron to filter contaminants such as virus, bacteria, colloid, particulates, trace pharmaceuticals in the water.
- ⑦ LED UV Lamp - kills bacteria and microorganisms (located in the lower tank).
- ⑧ LED UV lamp - kills bacteria and the remaining microorganisms (located in the upper tank)

6.12. Recirculated water - our exclusive technology ensures clean water recirculating through the internal water filters every 6 hours, so that the stored water always remains fresh and drinkable.

6.13. Protection against overheating - overheating protection will automatically switches AFA-AWG20L off when it detects overheating.

6.14. Protection against refrigerant leakage - AFA-AWG20L will be automatically switches off if refrigerant leak is detected.

Arrangement device

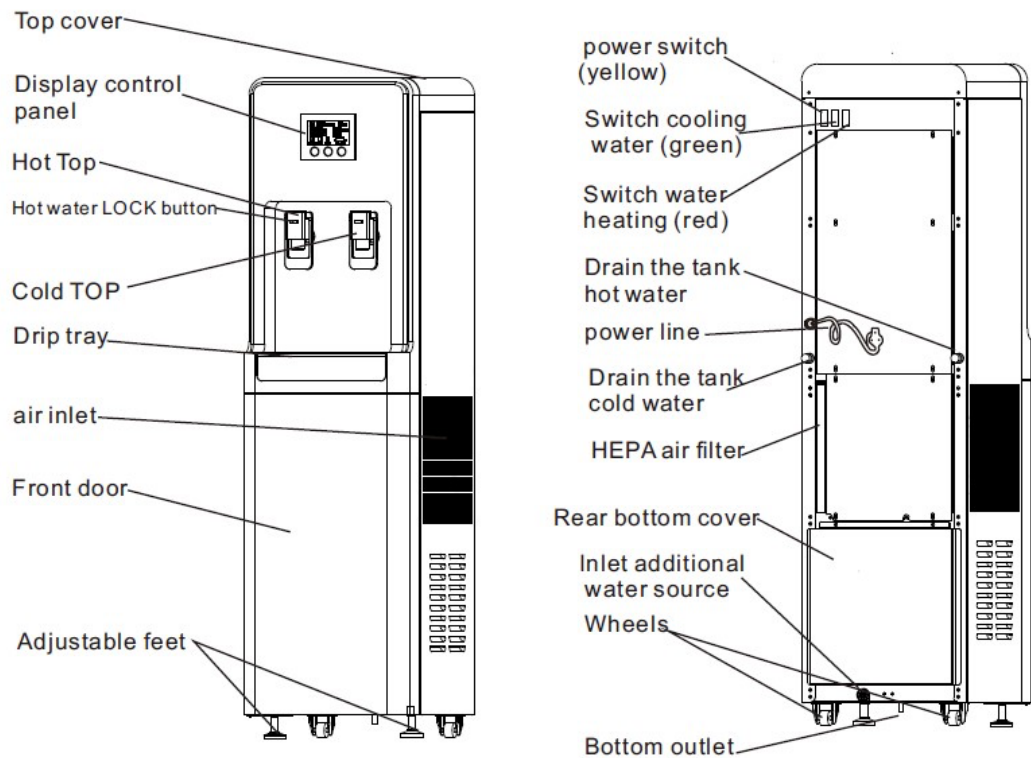

7. OPERATION

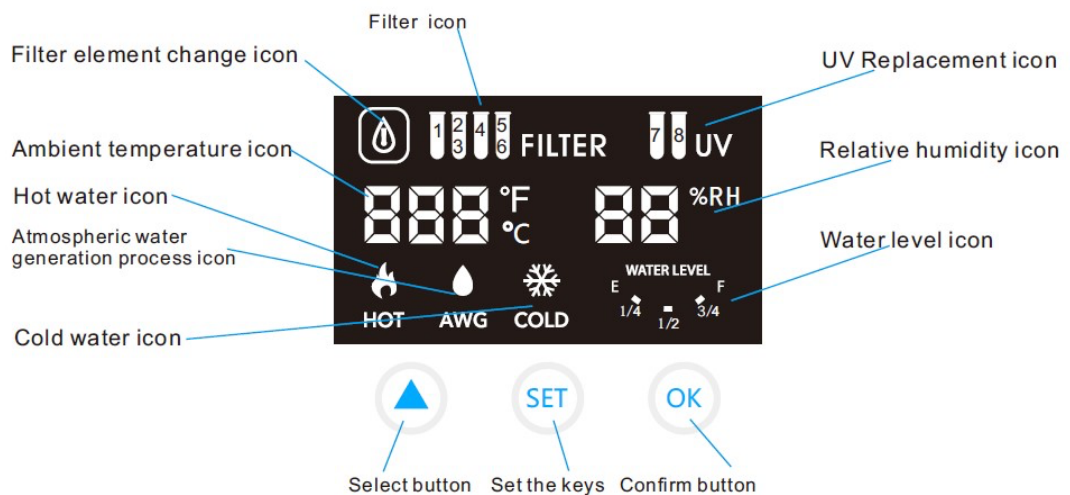

7.1: Filter element change icon-The icon flashes when the machine is in trouble, and does not shine when the fault is removed

7.2: Ambient temperature icon - measures the temperature around the device in degrees Celsius [°C] or Fahrenheit [°F].

7.3: Hot water icon - icon will flashes until water inside the tank heats up. Stays light on when water is heated to 85°C.

7.4: Atmospheric water generation process icon - While AFA-AWG20L is running and producing water, the icon stays light on

7.5: Cold water icon - icon will flash until the water inside the tank is cooled. Remains light on when the water is cooled to 6°C.

7.6: Relative humidity icon- shows the relative humidity in the surrounding area as a percentage [%]. Please be noted that AFA-AWG20L generates clean drinking water from 30% humidity above

7.7: Water level icon - shows the amount of water in the upper stainlesssteel tank in liters [L], scale consists of 4 sections, 1/4 stands for about 3.75L of the total 12L of the upper tank. AFA-AWG20L can continue produce water till the tank gets full. Drain will makes the bar disappear, water production fills it again.

7.8: Select button\Set the keys\Confirm button - Reset flashing filter warning

8. INITIAL COMMISSIONING

8.1. Unpack the cardboard box, remove the polystyrene cover and remove foil packaging of the device. Please keep the original packaging for possible warranty.

8.2. After unpacking, wait at least 24 hours before AFA-AWG20L plug into socket, failure to do so may damage the compressor. 8.3. Make sure AFA-AWG20L is not damaged or battered.

8.4. AFA-AWG20L must be located indoor, vertically and fixed on a flat floor 8.5. AFA-AWG20L is equipped with wheels at the lower rear side for easy moving on the floor

8.6. Place AFA-AWG20L in the space at least 30 cm from any walls or other structures from all sides and good air circulation

8.7. Before connecting AFA-AWG20L, check the tightness of all filters (Figure 1.2-4)

8.8. Connect AFA-AWG20L to an electrical outlet that is provided with a circuit breaker at least 10A

8.9. We recommend flushing after prolonged shutdown (see 11.1 Flushing the device)

8.10. We recommend connecting another source of water (see 12.

Connection of additional water sources)

8.11. Remove the plastic film from the control panel display

8.12. AFA-AWG20L is now ready for use.

9. DISPENSING OF WATER

9.1. AFA-AWG20L dispenses clean drinking water only after operational irrigation, i.e. filter irrigation and filling 1/4 of the upper tank, which corresponds to approx. 2.5 liters of water, such volume of water is minimal to ensure the correct operation of water recirculation according to the conditions of water production

9.2. The water heating and cooling switches must be on for at least 30 minutes to prepare the water to the required temperatures of 6°C (cold) and 85°C (warm)

9.3. Clean drinking water flows from the dispenser nozzle of AFA-AWG20L 9.4. Hold a glass or other water container under the dispenser nozzle of AFA-AWG20L, or stand drip tray

9.5. Press the anti-hot button of the hot tap and push the handle of the hot tap with the cup to get hot water.

9.6. Use the glass to push the handle of the cold tap to take cold water. 9.7. Please be noted that hot and cold water is only available when the heating and cooling switches are turned to the "ON" position on the back of AFA-AWG20L.

10. CHANGE FILTERS

AFA-AWG20L produces clean drinking water from the air by passing water through the filtration. Please follow the recommended filter change schedule to ensure the best water quality. The filter connectors are equipped with nonreturn valves. AFA-AWG20L will detect when it is time to replace the filter and will show the filter number ① - ⑧ on the display. Table below shows the recommended filter replacement schedule and the number of filters in AFA-AWG20L.

Air Filter.....	(*Every 3 months)
Softening Filter	(Every 6 months)
Sediment Filter	(Every 6 months)
Ultra-Fine Membrane Filter.....	(Every 12 months)
Pre-Carbon Filter	(Every 6 months)
Electropositive Membrane filter	(Every 6 months)
Bottom Tank LED-UV Lamp Filter.....	(Every 18 months)
Top Tank LED-UV Lamp Filter.....	(Every 18 months)

* Replacement depends on the degree of soiling or filter failure

Reset flashing filter warning

Press "SET" button 3 seconds and then press "Select Button" to Select the icon of the blinking filter element. After selecting, press "OK" button to clear the memory time of the current filter element and then start to remember the life of the newly replaced filter element.

10.1. Clean ① Air filter

- Unplug AFA-AWG20L (Figure 1.1-1)
- Pull out the air filter (Figure 1.1-2) and clean the dust on the surface of air filter directly with tap water or air, and then put it into the machine after cleaning.
- Reset the flashing filter warning NO.1 (see 10. "Resetting flashing filter warning")

Figure 1.1-1

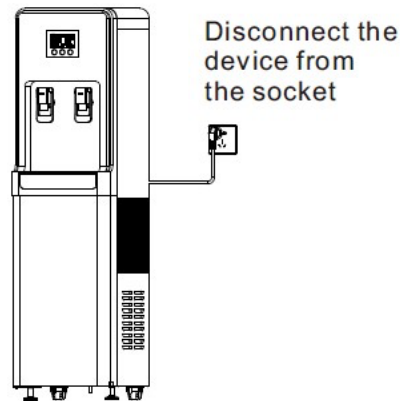
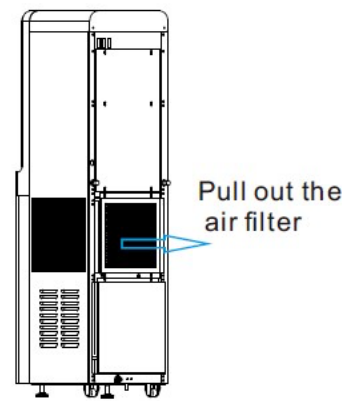

Figure 1.1-2



10.2. Replace water filters ② - ⑥

- a) Disconnect the plug (Figure 1.2-1)
- b) Open the front door on the right side of AFA-AWG20L (Figure 1.2-2)
- c) Remove the filter by turning counter clockwise (according to arrows on filter) and pull downwards (Figure 1.2-3)
- d) Keep in mind that filters are containing water and its removal may cause slight leakage of water, this is not a problem
- e) Insert new filter in place of the original by pressing upwards and turning it clockwise to fasten the filter (Figure 1.2-4)
- f) Make sure filter is properly tightened around the whole perimeter of the connection point
- g) Close the front door
- h) Reset the flashing filter warning - NO. 2 - 6 (see 10. "Resetting flashing filter warning")

Note: If you are replacing multiple filters, change water filters one by one

Figure 1.2-1

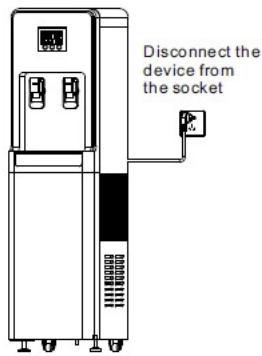

Figure 1.2-2

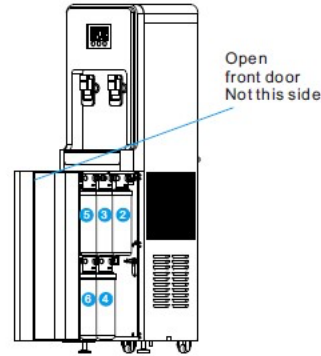

Figure 1.2-3

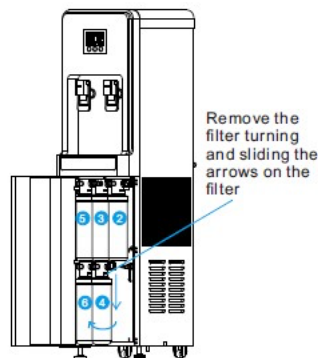
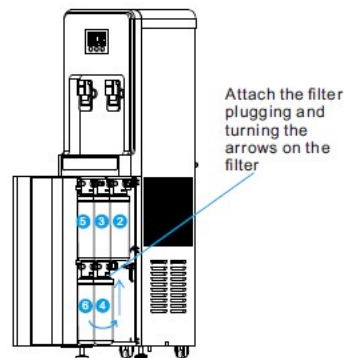

Figure 1.2-4



10.3. Replacing ⑦ LED UV lamp of the bottom tank

- a) Unplug AFA-AWG20L from the wall socket (Figure 1.3-1)
- b) Using a screwdriver or manually remove both screws from the back cover (Figure 1.3-2)
- c) Grasp the handle of the lower tank and slowly pull it towards you. Do not disconnect the tube and connectors, pour the remaining water out of the tank by tilting it (Figure 1.3-3)
- d) Loosen the LED-UV lamp nut from the underside with an adjustable wrench, disconnect the LED-UV lamp connector, remove the old LED-UV lamp (Figure 1.3-4)
- e) Put the new LED-UV lamp back into the tank and screw in with an adjustable wrench
- f) Check the connection of the new LED-UV lamp connector and its gasket (to test for leaks, pour water from the container back into the lower tank), carefully insert and then fasten the screws the rear lower cover
- g) Reset the blinking filter warning – NO. 7 (see 10. "Resetting flashing filter warning")

Figure 1.3-1

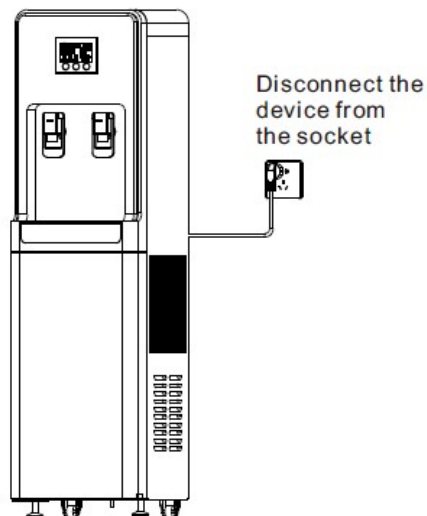

Figure 1.3-2

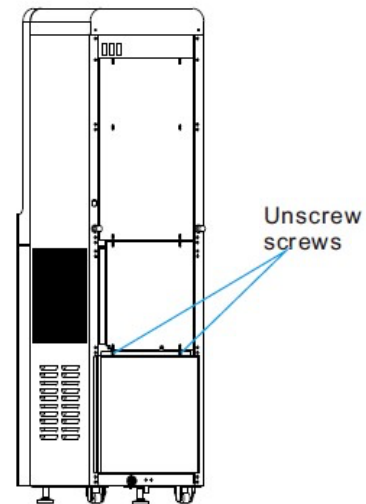

Figure 1.3-3

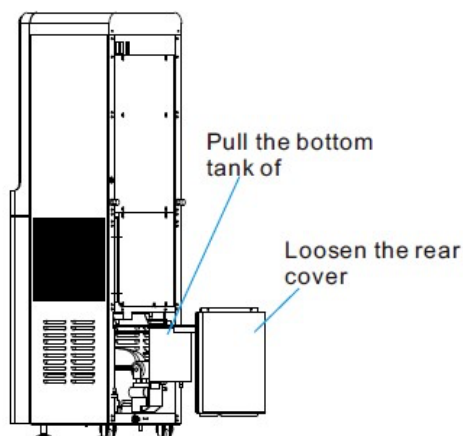
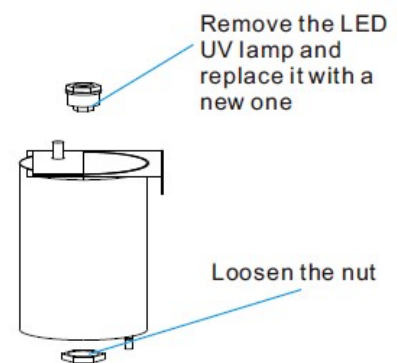

Figure 1.3-4



10.4. Replacing ⑧ LED-UV lamp of the top tank

- a) Unplug AFA-AWG20L from the wall socket (Figure 1.4-1)
- b) Open the drain valve of the cold and hot water tanks and empty the water stored in the water tank (Figure 1.4-2)
- c) Loosen the screws with a screwdriver and remove the cover and rear baffle (Figure 1.4-3)
- d) Lift the lid of the tank up (Figure 1.4-4)
- e) Loosen the LED-UV lamp nut from the underside with an adjustable wrench, disconnect the LED-UV lamp connector, remove the old LED-UV lamp (Figure 1.4-5)
- f) Put the new LED-UV lamp back into the tank and screw in with an adjustable wrench
- g) Check the connection of the new LED-UV lamp connector and its gasket (to test for leaks, pour water from the container back into the lower tank), carefully insert and then fasten the screws the rear lower cover
- h) Reset the blinking filter warning – NO.8 (see 10.3 "Reset the blinking filter warning")
- j) Personal safety concerns require a professional replacement

Figure 1.4-1

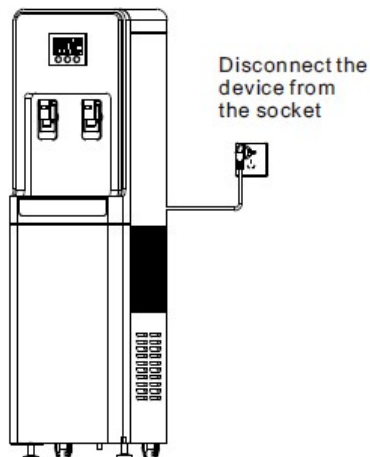

Figure 1.4-2

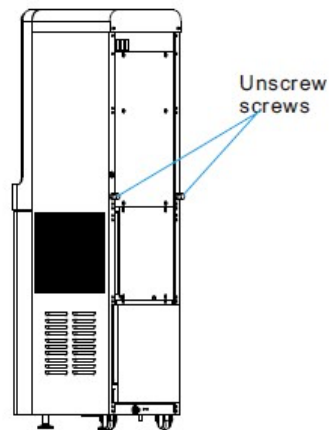

Figure 1.4-3

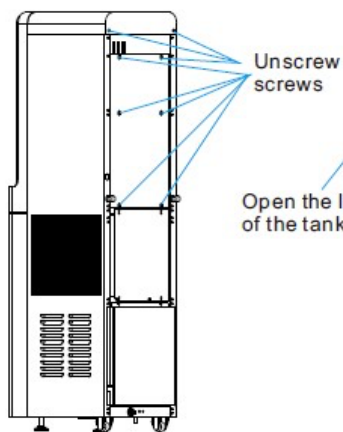

Figure 1.4-3

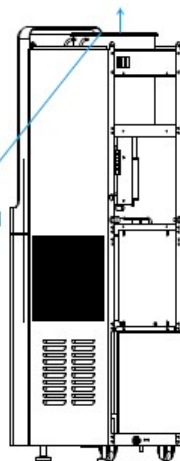
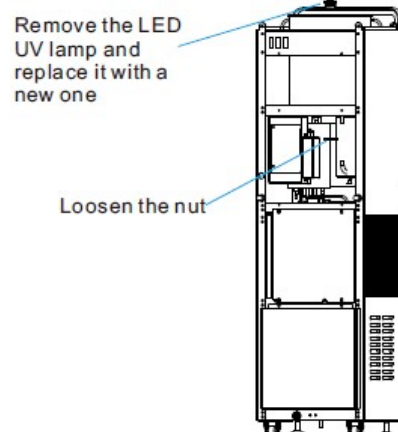

Figure 1.4-5



11. THE FLUSH, CLEANING AND DISINFECTION.

- 1) Always wipe AFA-AWG20L with clean, soft and damp cloth.
- 2) If the air quality is not good, suggest to use water flush or use food grade citric acid to clean the lower and upper stainless steel tanks monthly.
- 3) If AFA-AWG20L is switched off for more than two days, drain the water from all tanks and filters and then rinse before using it again.
- 4) If AFA-AWG20L is switched off for longer than one week, suggest to replace water filters and machine should be disinfected totally, especially in the hot weather.

Figure 2.1-1

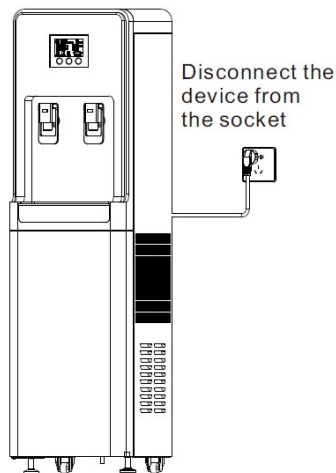

Figure 2.1-2

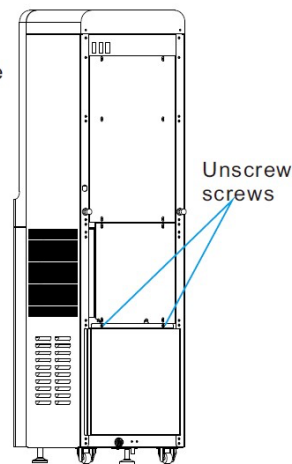
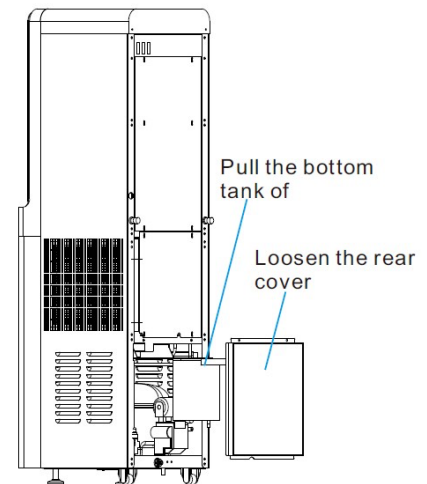

Figure 2.1-3



11.1. Flushing the device

- a) This step will require 10-15 liters of purified or distilled water
- b) If AFA-AWG20L is connected to an additional water supply, then turn the pressure valve lever to the “CLOSED” position and follow the next steps, otherwise leave the lever in the “OPEN” position and let the water automatically pour into the tank (the water level indicator icon will show one division), then turn the valve to the “CLOSED” position, continue according to h) and then open the valve to the “OPEN” position, ending with d)
- c) Using a hand or a screwdriver, remove both screws from the back cover (Figure 2.1-2)
- d) Grasp the handle of the lower tank and slowly pull it towards you, do not disconnect the tube and connectors, pour the remaining water out of the tank by tilting (Figure 2.1-3)
- e) Slowly fill the bottom tank with clean or distilled water
- f) Let the pump drain the water from the bottom tank and then refill, repeat this step up to 10-15 liters of distilled or purified water
- g) Carefully insert the lower tank and fasten the rear lower cover bolts
- h) Allow AFA-AWG20L to perform a water recirculation process, which may take up to three hours
- i) AFA-AWG20L is now ready for use again

11.2. Cleaning the bottom tank

- a) Disconnect the device from the power supply (Figure 2.1-1)
- b) Use a screwdriver or manually remove the two screws from the rear cover (Figure 2.1-2)
- c) Grasp the handle of the bottom tank and slowly pull it towards you, disconnect tubing and connectors, pour the remaining water from the tank by tilting (Figure 2.1-3)
- d) Wipe the walls of the tank with a clean, soft, damp cloth

- e) Gently push the bottom tank inside and fasten bolts of the rear cover. If required, reset the flashing filter warning - NO. 7 (see 10. "Resetting flashing filter warning")

11.3. Device disinfection

11.3.1 - Clean with food grade citric acid.

- 1) Shutdown the AFA-AWG20L.
- 2) Remove filters.
- 3) Suggest to use food grade citric acid liquid and mix it with water according to the instructions of the citric acid product. If the internal pollution is critical, it is recommended to have a higher concentration citric acid liquid. Approximately 13-15L of the total liquid needs to be prepared in advance.
- 4) Wear rubber gloves, use a soft bristled brush and cleaning cloth dipped in citric acid liquid, and clean the upper and lower water tank, especially for obvious stains.
- 5) Slowly add the citric acid liquid into the upper water tank until the water in the upper water tank is full, which also means that the cold and hot water tanks are also full.
- 6) Keep it for 30 minutes.
- 7) Drain the citric acid liquid through the drainage port at the back of the machine.

11.3.2 - Clean with tap water after steps of using food grade citric acid liquid.

- 1) Restore all components of AFA-AWG20L, cover the upper water tank, and install filters into the machine.
- 2) Power on AFA-AWG20L.
- 3) Add tap water into the lower water tank until the screen shows the water level is Full.
- 4) Drain the water through the drainage port at the back of the machine.
- 5) Repeat the process 3 times.
- 6) During the fourth operation, get water from the hot and cold water faucets, throw away the first water directly, and check if there are any mucus or bad smell in the second water.

If not, it means the problem has been resolved.

If there is still any, it may indicate that the current filters have gone bad and need to be replaced.

12. CONNECTION OF ADDITIONAL WATER RESOURCES

Setting contents: Pressure hose blue 4,5m, pressure water valve 1/2'

- a) Remove the plug from the additional water supply at the back of the device by pushing the gray O-ring apart, if this plug is missing, contact your supplier
- b) Install the pressure valve into a 1/2' water supply outlet using a Teflon thread or tape keep in mind that the person's professional (plumber) is required for this step and some countries may require pressure test of installed valve, maximum permissible pressure in the pipeline is 4 bar.

- c) Please be noted that the connection for the valve from the connection set may vary, it may be of a size other than 1/2', use a brass adapter or adapter (not included) Insert the supplied pressure blue hose into the inlet of the additional water supply and attach the other end of the hose by tightening the nut to the pressure valve
- e) Turn the pressure valve lever to the "OPEN" position, check the joints for leaks
- f) AFA-AWG20L is now ready to take water from the additional water source. If you do not need to draw water from the additional water supply, turn the pressure valve lever to the "CLOSED" position and disconnect the hose from the additional water supply inlet at the back of the bottom of AFA-AWG20L.

13. COMPLETE DRAINAGE

- a) If AFA-AWG20L is connected to an optional water source, then rotate the pressure lever on the valve to "closed" position and disconnect the tubing from the supply of additional water source on the rear side of the bottom of AFA-AWG20L
- b) Turn the heating and cooling of water to the "OFF" position
- c) Dispense all hot water using the hot water button
- d) Dispense all cold water using the cold water button
- e) Remove AFA-AWG20L from the wall (Figure 3.1-1)
- f) Hold the vessel in the water tank hot water outlet
- g) Remove plastic cap, remove rubber stopper and completely empty the tank, the water that flows out can be used for consumption, it's not need to be disposed (Figure 3.1-2)
- h) Hold the vessel in the water drain tank of cold water and repeat step g)
- i) Replace the rubber stopper and screw the plastic caps back on each outlet
- j) Open the front door on the right hand side and gradually remove the filters by turning counter clockwise (according to the arrows on the filter) and pull downwards (Figure 1.2-3). Remove filters and close the front panel, keep in mind that filters are filled with water and when removing there may be a small water leak, this is not a problem.
- k) Use a screwdriver or manually remove the two screws from the back cover, hold the handle of the tank bottom and slowly pull it towards you; disconnect tubing and connectors, pour the remaining water from the tank by tilting (Figure 3.1-4).
- l) Gently push the bottom tank inside and fasten bolts of the rear cover.

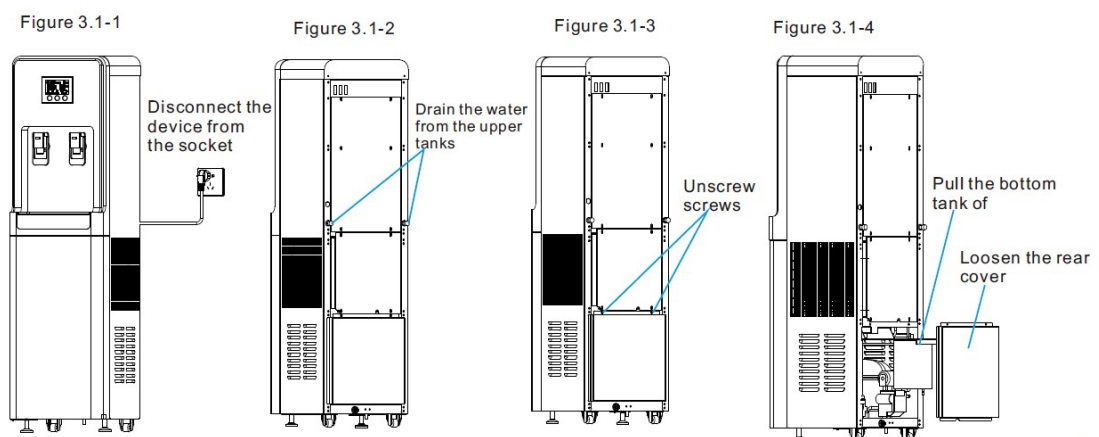

14. TROUBLE SHOOTING

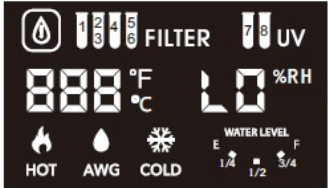
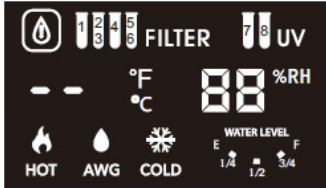
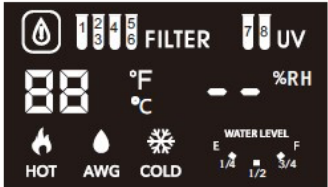
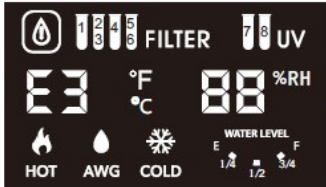
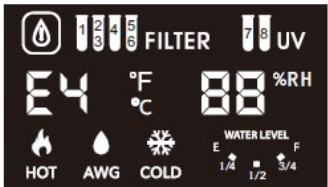
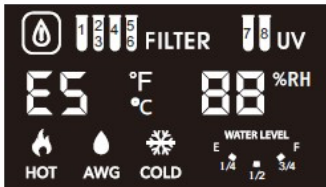
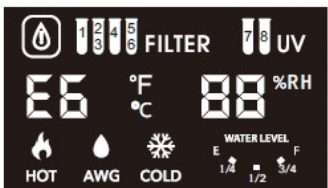
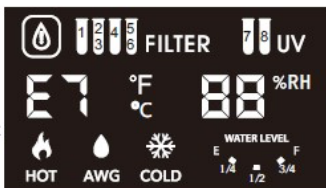
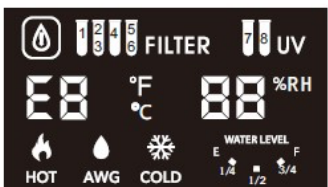
	LO - Low humidity around (\geq working 20%)		-- Error sensor temperature
	-- Error sensor temperature and humidity		E3 - Error sensor defrost
	E4 - Error sensor hot water		E5 - Error sensor cold water
	E6 - Error cooling system - Protection of low pressure - Possible refrigerant leakage		E7 - Possible water leak
	E8 - Waterway jam		

15. SOLUTION OF OTHER PROBLEMS

15.1. AFA-AWG20L does not turn on

- Check that the device is connected to the power supply
- Check that the power plug is not damaged

15.2. The unit turns on but does not generate water

- Check the room temperature – AFA-AWG20L's operating temperature range is 15°C to 45°C
- Check humidity - Minimum relative humidity - 30%
- Check air filter for contamination - Replace as necessary
- Check the heat exchanger fins for contamination – AFA-AWG20L must be disassembled for this inspection which can only be done with an authorized service center.

Be noted: Please disconnect AFA-AWG20L from the power supply before carrying out any service or maintenance work.

15.3. AFA-AWG20L operates noisy, vibrates or seeps water

- a) Check that AFA-AWG20L is in a vertical position on a flat surface
- b) Check that the internal condensate collector and adapter are clean - The unit must be disassembled for such inspection which can only be done with an authorized service center.

If AFA-AWG20L still does not operate properly after performing the above steps, contact your supplier. Only professional technicians can carry out work related to the cooling and electrical system.

16. TECHNICAL SPECIFICATIONS

AFA-AWG20L can produce 20L/Day pure water from air @30°C & RH-80%.

- 1) Input Power: 470W (Production) + 500W (Heating)
- 2) Power Supply: AC 110V 60Hz / AC 220V 50Hz
- 3) Refrigerant: R134a
- 4) Filtration Steps: Air Filter + Softening Filter + Sediment Filter + Ultra-Fine Membrane Filter + Pre-Carbon Filter + Electropositive Membrane filter + 2 LED-UV lamps.
- 5) Preset Hot 85°C & Cold 6°C
- 6) Working Temperature: 15-45°C
- 7) Working Humidity: RH 30% above
- 8) Net Dimension & Weight: 37.5*30.7*115.4CM, 42KG
- 9) LCD Touch Screen Display
- 10) Indoor Lifestyle and Low Noise Level

Remark:

Appliances must be disposed of at a designated recycling point for the disposal of electrical and electronic equipment.

It is required by law that all used electronic products (which includes products containing ultraviolet lamps) must be recycled/disposed-of separately from everyday household waste.